

MasterColor® Metal Halide 250W HPS-Retro White™ Lamp

Featuring ALTO® Lamp Technology

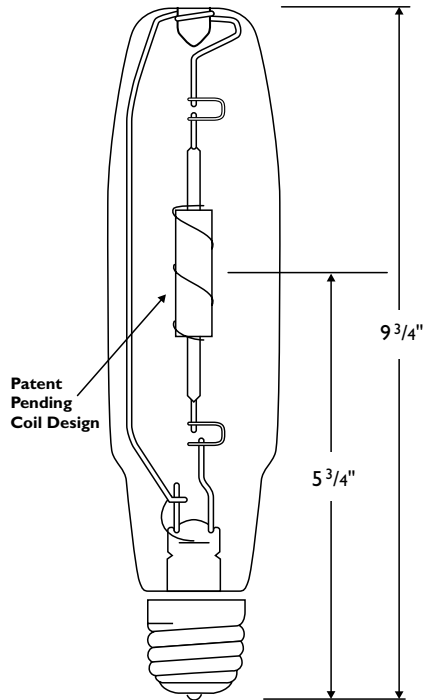

Ordering Information

Ordering Code	CDM250S50/V/O/4K
ANSI Designation	Operates on S50
Product Number	I30930
Description	MasterColor Metal Halide
Package Quantity	12

Physical Characteristics

Bulb Size	ED-18
Bulb Finish	Clear
Base	Mogul
Max. Overall Length (MOL)	9 3/4" (248mm)
Light Center Length (LCL)	5 3/4" (146mm)
Arc Length	1" (25.4mm)
Arc Tube Material	Poly Crystalline Alumina
Max. Permissible Bulb Temp.	400°C (752°F)
Max. Permissible Base Temp.	210°C (410°F)
Max. Bulb to Base Eccentricity	3°
Max. Arc Tube to Base Eccentricity	3°

Operating Characteristics (Photometric)

Rated Initial Lumens ¹	22,500
Mean Lumens, Approx. ²	19,125
Rated Average Life, Hours	20,000
Correlated Color Temp. (CCT) ²	4000K
CIE Chromaticity Approx. ²	x-.378, y-.370
Color Rendering Index (CRI)	85
Efficacy (lpw)	90

Operating Position

Base Up or Base Down ± 15°—Open or Enclosed Luminaires

MasterColor® Spectral Power Distribution—4K Types

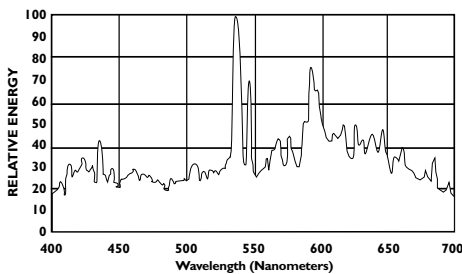

CDM 250 S50/V/O/4K Lumen Maintenance

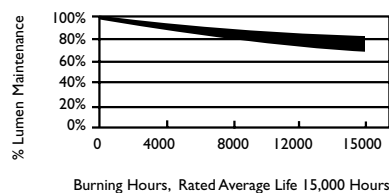

PHILIPS

MasterColor® Metal Halide 250 Watt HPS-Retro White™ Lamp Featuring ALTO® Lamp Technology

Electrical Data (Subject to change without notice)

Lamp Watts (Nominal)	250
Lamp Operating Voltage (rms) (Nominal) ²	100
Initial Lamp Voltage Range (rms) ³	90–120
Lamp Operating Current (Amps) (rms) (Nominal)	3.0
Lamp Current Crest Factor (Maximum)	1.8
Warm-up Time to 80% of Output	2 Minutes
Restrike Time for Hot Lamp	15 Minutes (Average)
Ballast Type	ANSI S50
Ballast Open Circuit Voltage (Minimum)	198 RMS Min.
Pulse Peak Volts	2500 Minimum, 4000 Maximum
Pulse Width @ 90% Peak	1 Micro Second Minimum
Pulse Repetition Rate (Minimum)	1 per Half Cycle
Minimum Operating Temperature	-30° C

1) Measured at 100 hours of life in vertical position.

2) Measured at rated lamp watts on a linear reactor. LPW does not include ballast losses.

3) Measured with the lamp operating at rated watts

Warnings, Cautions and Operating Instructions

R

“**WARNING:** These lamps can cause serious skin burn and eye inflammation from short wave ultraviolet radiation if outer envelope of the lamp is broken or punctured. Do not use where people will remain for more than a few minutes unless adequate shielding or other safety precautions are used. Certain lamps that will automatically extinguish when the outer envelope is broken or punctured are commercially available.” This lamp complies with FDA radiation performance standard 21 CFR subchapter J. (USA:21CFR 1040.30 Canada: SOR/DORS/80-381)

If the outer bulb is broken or punctured, turn off at once and replace the lamp to avoid possible injury from hazardous short wave ultraviolet radiation. Do not scratch the outer bulb or subject it to pressure as this could cause the outer bulb to crack or shatter. A partial vacuum in the outer bulb may cause glass to fly if the envelope is struck.

WARNING: The arc-tube of metal halide lamps is designed to operate under high pressure and at temperatures up to 1000°C and can unexpectedly rupture due to internal or external factors such as a ballast failure or misapplication. If the arc-tube ruptures for any reason, the outer bulb may break and pieces of extremely hot glass might be discharged into the surrounding environment. If such a rupture were to happen, **THERE IS A RISK OF PERSONAL INJURY, PROPERTY DAMAGE, BURNS AND FIRE.**

These lamps are designed to retain all the glass particles should an arc tube rupture occur. The following operating instructions are recommended to minimize these occurrences.

RELAMP FIXTURES AT OR BEFORE THE END OF RATED LIFE.
Allowing lamps to operate until they fail is not advised and may increase the possibility of inner arc tube rupture.

This lamp contains an arc tube with a filling gas containing Kr-85 and is distributed by Philips Lighting Company, a division of Philips Electronics North America Corporation, Somerset, New Jersey 08875-6800.

CAUTION: TO REDUCE THE RISK OF PERSONAL INJURY, PROPERTY DAMAGE, BURNS AND FIRE RESULTING FROM AN ARC-TUBE RUPTURE THE FOLLOWING LAMP OPERATING INSTRUCTIONS MUST BE FOLLOWED.

Lamp Operating Instructions:

- 1) **RELAMP FIXTURES AT OR BEFORE THE END OF RATED LIFE.** Allowing lamps to operate until they fail is not advised and may increase the possibility of inner arc tube rupture.
- 2) Before lamp installation/replacement, shut power off and allow lamp and fixture to cool to avoid electrical shock and potential burn hazards.
- 3) Use only auxiliary equipment meeting Philips and/or ANSI standards. Use within voltage limits recommended by ballast manufacturer.
 - A. Operate lamp only within specified limits of operation.
 - B. For total supply load refer to ballast manufacturers electrical data.
- 4) Periodically inspect the outer envelope. Replace any lamps that show scratches, cracks or damage.
- 5) If a lamp bulb support is used, be sure to insulate the support electrically to avoid possible decomposition of the bulb glass.
- 6) Protect lamp base, socket and wiring against moisture, corrosive atmospheres and excessive heat.
- 7) Time should be allowed for lamps to stabilize in color when turned on for the first time. This may require several hours of operation, with more than one start. Lamp color is also subject to change under conditions of excess vibration or shock, and color appearance may vary between individual lamps.
- 8) Lamps may require 10–20 minutes to re-light if there is a power interruption.
- 9) Take care in handling and disposing of lamps. If an arc tube is broken, avoid skin contact with any of the contents or fragments.

